

12. Channels ㄷ형강

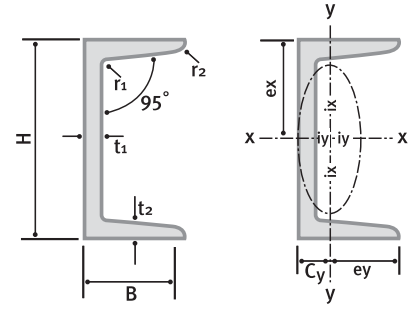

Dimensions and Sectional Properties 치수 및 단면성능

KS D 3503, 3515/3502

표준 단면 치수 Standard Sectional Dimension(mm)					단면적 Sectional Area(cm ²)	단위무게 Unit Weight (kg/m)	중심의 위치 Center of Gravity(cm)	단면 2차 모멘트 Moment of Inertia(cm ⁴)		단면 2차 반경 Radius of Gyration(cm)		단면계수 Modulus of Section(cm ³)	
H x B	t ₁	t ₂	r ₁	r ₂	A	W	C _y	I _x	I _y	i _x	i _y	S _x	S _y
*75 x 40	5	7	8	4	8.818	6.92	1.28	75.3	12.2	2.92	1.17	20.1	4.47
*100 x 50	5	7.5	8	4	11.92	9.36	1.54	188	26.0	3.97	1.48	37.6	7.52
125 x 65	6	8	8	4	17.11	13.4	1.90	424	61.8	4.98	1.90	67.8	13.4
150 x 75	6.5	10	10	5	23.71	18.6	2.28	861	117	6.03	2.22	115	22.4
200 x 80	7.5	11	12	6	31.33	24.6	2.21	1,950	168	7.88	2.32	195	29.1
200 x 90	8	13.5	14	7	38.65	30.3	2.74	2,490	277	8.02	2.68	249	44.2
250 x 90	9	13	14	7	44.07	34.6	2.40	4,180	294	9.74	2.58	334	44.5
300 x 90	9	13	14	7	48.57	38.1	2.22	6,440	309	11.5	2.52	429	45.7
380 x 100	10.5	16	18	9	69.69	54.5	2.41	14,500	535	14.5	2.78	763	70.5
*380 x 100	13	20	24	12	85.71	67.3	2.54	17,600	655	14.3	2.76	926	87.8

Note : *는 별도주문판매(These sizes indicated by an asterisk*) are not included in regular rolling schedules.)

13. Parallel Flange Channels 평행채널

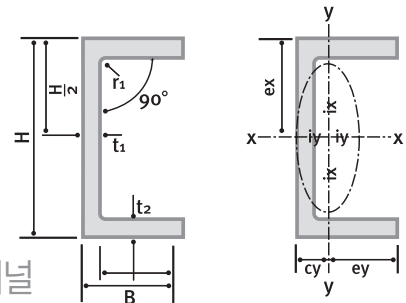

Dimensions and Sectional Properties 치수 및 단면성능

표준 단면 치수 Standard Sectional Dimension(mm)					단면적 Sectional Area(cm ²)	단위무게 Unit Weight (kg/m)	중심의 위치 Center of Gravity(cm)	단면 2차 모멘트 Moment of Inertia(cm ⁴)		단면 2차 반경 Radius of Gyration(cm)		단면계수 Modulus of Section(cm ³)	
H x B	t ₁	t ₂	r ₁	r ₂	A	W	C _y	I _x	I _y	i _x	i _y	S _x	S _y
100 x 50	4.5	7.5	8	-	11.6	9.1	1.71	189	28.5	4.0	1.6	37.7	8.6
125 x 65	5.5	8	8	-	16.7	13.1	2.14	424	70.3	5.0	2.1	67.8	16.1
150 x 75	6	10	10	-	23.2	18.2	2.54	864	131.3	6.1	2.4	115.1	26.5
200 x 80	6.5	11.5	12	-	30.5	24.0	2.55	1,984	192.5	8.1	2.5	198.4	35.3
200 x 90	7.5	13.5	14	-	38.1	29.9	3.02	2,501	305.7	8.1	2.8	250.1	51.1
250 x 90	8.5	13	14	-	43.3	34.0	2.64	4,187	329.2	9.8	2.8	335.0	51.8
300 x 90	8.5	13	14	-	47.5	37.3	2.44	6,432	348.5	11.6	2.7	428.8	53.2
380 x 100	10	16	18	-	68.2	53.5	2.63	14,527	592.6	14.6	2.9	764.6	80.4